

| REVISIONS |                           |           |          |
|-----------|---------------------------|-----------|----------|
| REV       | DESCRIPTION, ECN, EAR NO. | DATE      | APP'D    |
| A         | PROPOSAL                  | FEB 14/25 | Chigow.X |
| B         | UPDATE PCB NOTE ON PAGE 3 | MAR 05/25 | Chigow.X |

AMPHENOL PART NUMBER CNFIGURATION  
V94 - A D Z 2 3 - X 0 A S S X A

PLATING OPTION

3 - 30µ" GOLD PLATING ON MATING AREA  
150~300µ" MATTE TIN ON TERMINATION  
OVER50µ"(1.27 µm) MIN. NICKEL UNDER LAYER

6 - 15µ" GOLD PLATING ON MATING AREA  
150~300µ" MATTE TIN ON TERMINATION  
OVER50µ"(1.27 µm) MIN. NICKEL UNDER LAYER

PACKAGE  
A - TRAY

SOLDER RING OPTIONS  
0 - NO SOLDER RING  
1 - WITH SOLDER RING

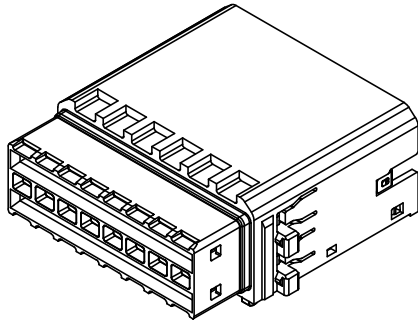

V94-ADZ23-X0ASS1A

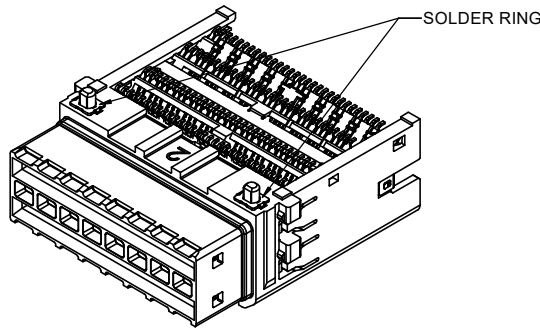

V94-ADZ23-X0ASS1A

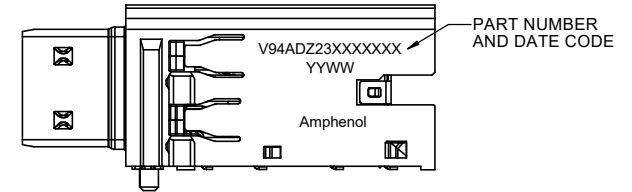

PART NUMBER AND DATE CODE

NOTES:

1. MATERIAL:

- CONTACTS: COPPER ALLOY.
- PLATING: SEE PART NUMBER.
- MOLDING: LCP UL RATED 94 V-0, (COLOR BLACK).
- HOUSING: LCP UL RATED 94 V-0, (COLOR BLACK).

2. PACKAGING: TRAY.

3. TEMPERATURE RANGE: -40°C TO 85°C.



|   |          |           |       |   |
|---|----------|-----------|-------|---|
| Release Level   | In Work  | ECN       | (ecm) | <b>Amphenol High Speed Interconnects</b><br>A Division of Amphenol Corp. www.amphenol-hcc.com<br>Title:<br>CDFP SMT<br>1XN CONNECTOR GEN 6<br>Product Family: CDFP<br>Dwg. No. P-V94-ADZ23<br>REV B |
| Drawn   | BROOK.J  | 2025/2/14 |       |   |
| Designed  | BROOK.J  | 2025/2/14 |       |   |
| Guardian  | MICHAELS | 2025/2/14 |       |   |
| Approver  | CHIGOW.X | 2025/2/14 |       |   |
| TOLERANCES UNLESS OTHERWISE SPECIFIED:<br>Linear .XX ±0.25<br>.XXX ±0.15<br>.XXX ±0.05<br>Angular ° ±2° |          |           |       |   |
| Drawing Units: mm<br>Scale: 2:1   Dwg Size: A2   Product - Production Dwg                               |          |           |       | SHEET 1 OF 3  |

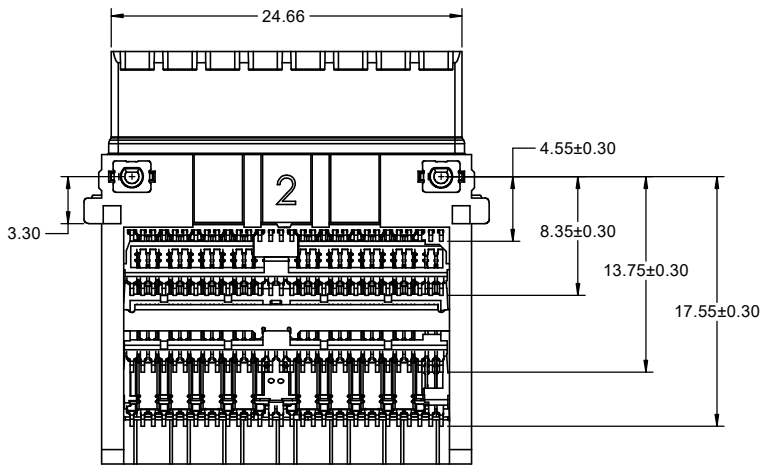
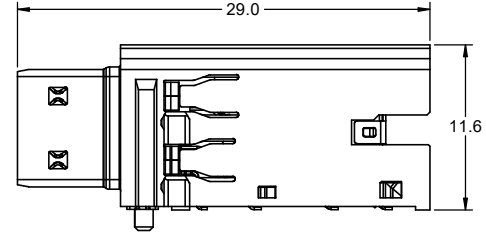
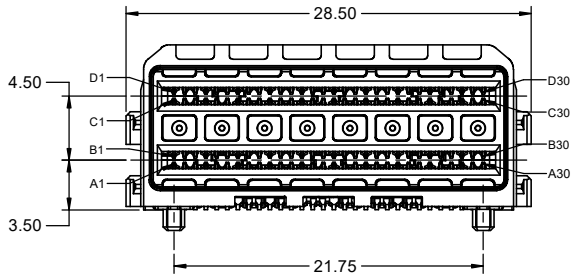

| REVISIONS   |                           |      |       |
|-------------|---------------------------|------|-------|
| REV         | DESCRIPTION, ECN, EAR NO. | DATE | APP'D |
| SEE SHEET 1 |                           |      |       |

|                                       |              |                          |  |   |
|---------------------------------------|--------------|--------------------------|--|---|
| Release Level                         | In Work      | ECN                      | (ecm)                                    | <b>Amphenol High Speed Interconnects</b><br>A Division of Amphenol Corp. www.amphenol-hcc.com<br>Title:<br>CDFP SMT<br>1XN CONNECTOR GEN 6<br>Product Family: CDFP<br>Dwg. No. P-V94-ADZ23<br>REV B |
| Drawn                                 | BROOK, J     | 2025/2/14                |  |   |
| Designed                              | BROOK, J     | 2025/2/14                |  |   |
| Guardian                              | MICHAELS     | 2025/2/14                |  |   |
| Approver                              | CHIGOW, X    | 2025/2/14                |  |   |
| TOLERANCES UNLESS OTHERWISE SPECIFIED |              |                          |  |   |
|                                       |              | Linear                   | X.XX ±0.25<br>X.XXX ±0.15<br>X.XXX ±0.05 |   |
|                                       |              | Angular                  | °<br>' ±2"                               |   |
| Drawing Units: mm                     |              |                          |  |   |
| Scale: 2:1                            | Dwg Size: A2 | Product - Production Dwg |  | SHEET 2 OF 3  |

© 2020 AMPHENOL CANADA CORP.

© 2020 AMPHENOL CANADA CORP.

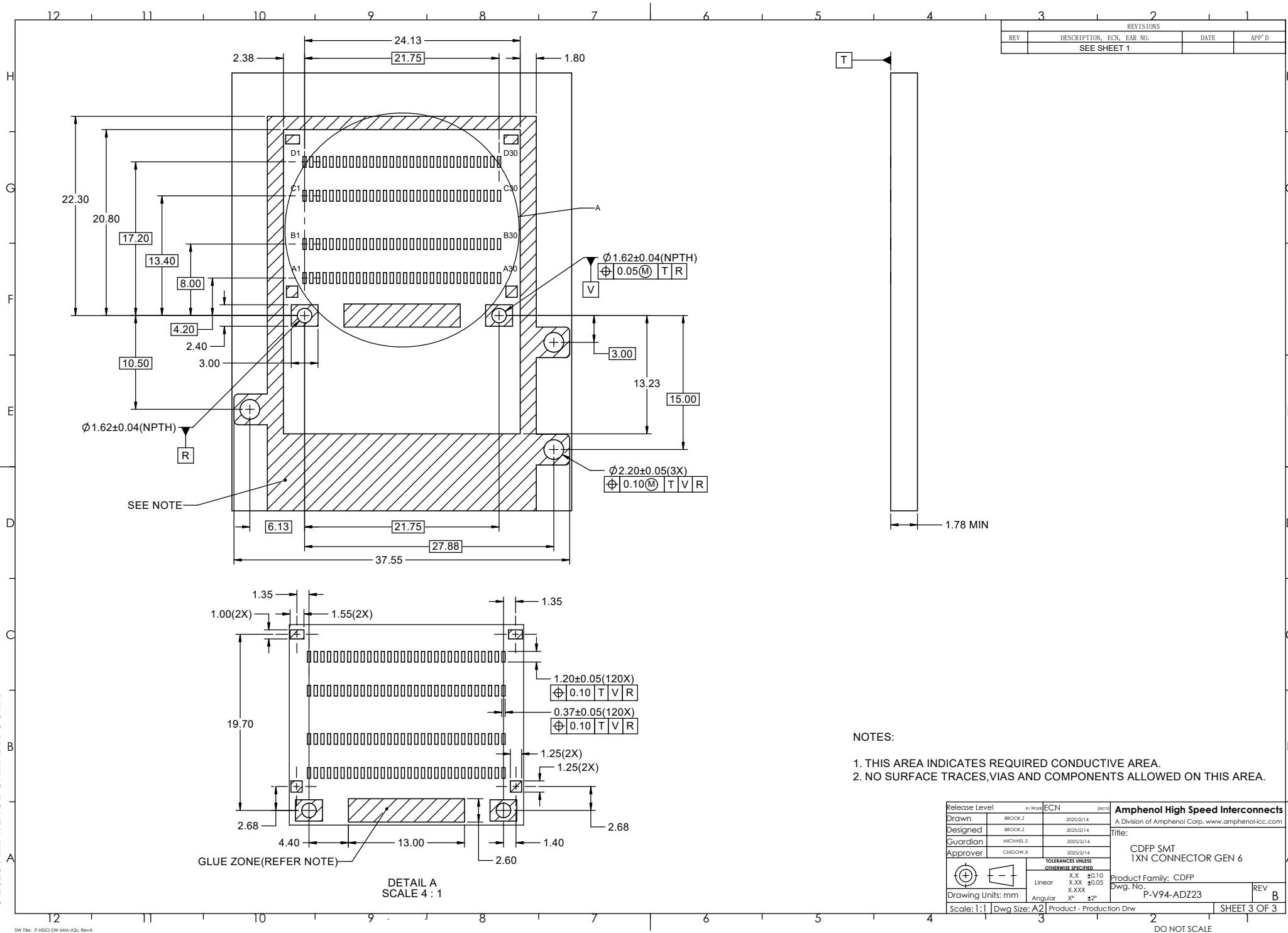

| REVISIONS   |                           |      |       |
|-------------|---------------------------|------|-------|
| REV         | DESCRIPTION, ECN, EAR NO. | DATE | APP'D |
| SEE SHEET 1 |                           |      |       |

- NOTES:
1. THIS AREA INDICATES REQUIRED CONDUCTIVE AREA.
  2. NO SURFACE TRACES, VIAS AND COMPONENTS ALLOWED ON THIS AREA.

|   |           |           |        |  |
|---|-----------|-----------|--------|--|
| Release Level   | In Work   | ECN       | (tech) | <b>Amphenol High Speed Interconnects</b><br>A Division of Amphenol Corp. www.amphenol-hcc.com<br>Title:<br>CDFP SMT<br>1XN CONNECTOR GEN 6<br>Product Family: CDFP<br>Dwg. No. P-V94-ADZ23 |
| Drawn   | BROOK, J  | 2025/2/14 |        |  |
| Designed  | BROOK, J  | 2025/2/14 |        |  |
| Guardian  | MICHAELS  | 2025/2/14 |        |  |
| Approver  | CHIGOW, X | 2025/2/14 |        | REV B  |
| TOLERANCES UNLESS OTHERWISE SPECIFIED:<br>Linear .XX ±0.10<br>.XXX ±0.05<br>.XXX<br>Angular ° ±2° |           |           |        |  |
| Drawing Units: mm<br>Scale: 1:1   Dwg Size: A2   Product - Production Dwg                         |           |           |        | SHEET 3 OF 3   |