

8 7 6 5 4 3 2 1

MATERIAL:
 PLASTIC HOUSING:
 LCP, FLAMMABILITY RATING UL94-V0
 CONTACT:
 COPPER ALLOY
 PLATING:
 SEE AMPHENOL PART NUMBER
 PACKAGING: TAPE AND REEL
 TEMPRATURE RANGE: -40°C TO +85°C

REVISIONS			
REV.	DESCRIPTION/ECN	DATE	APPROVED
B	UPDATED PCB	10-NOV-21	J.SI
C	UPDATED DRAWING	18-MAY-22	J.SI
D	UPDATED INK MARKING LOCATION	04-AUG-22	J.SI

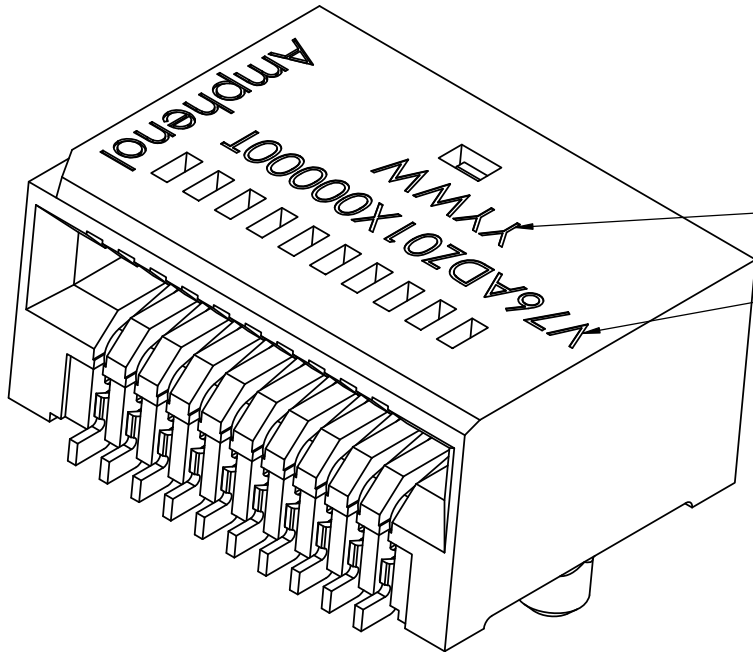

DATE CODE
 PART NUMBER

AMPHENOL PART NUMBER CONFIGURATION

V76-ADZ01-X 00000 T

- PACKAGING
T= TAPE AND REEL PACKAGING
- PLATING (NICKEL UNDER PLATED OVER ALL)
- 2= 0.76µm Au AT MATING AREA, GOLD FLASH AT SMT AREA
- 3= 0.76µm Au AT MATING AREA, 3.0~7.62µm MATTE TIN AT SMT AREA
- 5= 0.38µm Au AT MATING AREA, GOLD FLASH AT SMT AREA
- 6= 0.38µm Au AT MATING AREA, 3.0~7.62µm MATTE TIN AT SMT AREA

Release Level	In Work	ECN	(ecn)	Amphenol High Speed Interconnects A Division of Amphenol Corp. www.amphenol-icc.com Title: SFP 112G 1XN CONNECTOR ASSEMBLY Product Family: V76 Dwg. No. P-V76-ADZ01 REV D
Drawn	GALEN LIU	2021-04-27		
Designed	GALEN LIU	2021-04-27		
Guardian	MIKE HUANG	2021-04-27		
Approver	JASON SI	2021-04-27		
		TOLERANCES UNLESS OTHERWISE SPECIFIED		
Drawing Units: mm		Linear	X.X ±0.38 X.XX ±0.25 X.XXX ±0.15 Angular X° ±2°	
Scale: 10:1		Dwg Size: A3		Product - Customer Drw
				SHEET 1 OF 3



© 2020 AMPHENOL CANADA CORP.

© 2020 AMPHENOL CANADA CORP.

REVISIONS			
REV.	DESCRIPTION	DATE	APPROVED
-	SEE SHEET 1	-	-

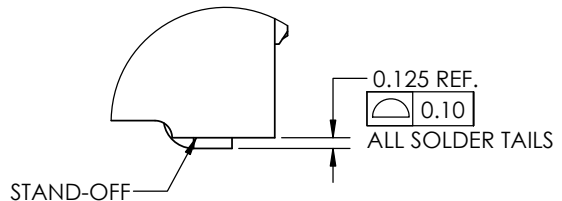
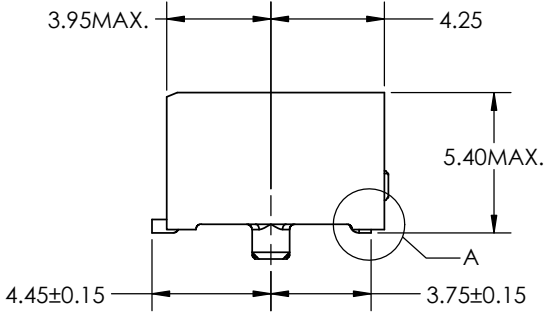
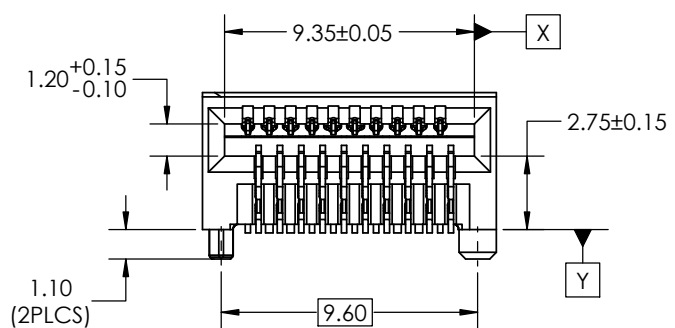
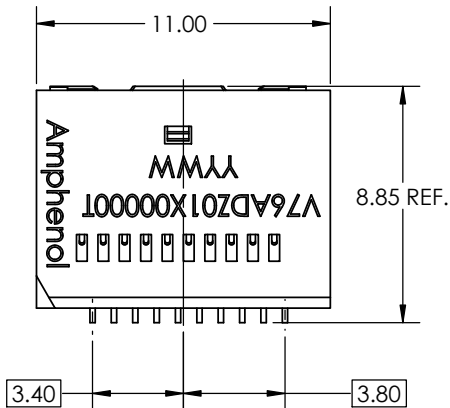

DETAIL A
SCALE 16:1

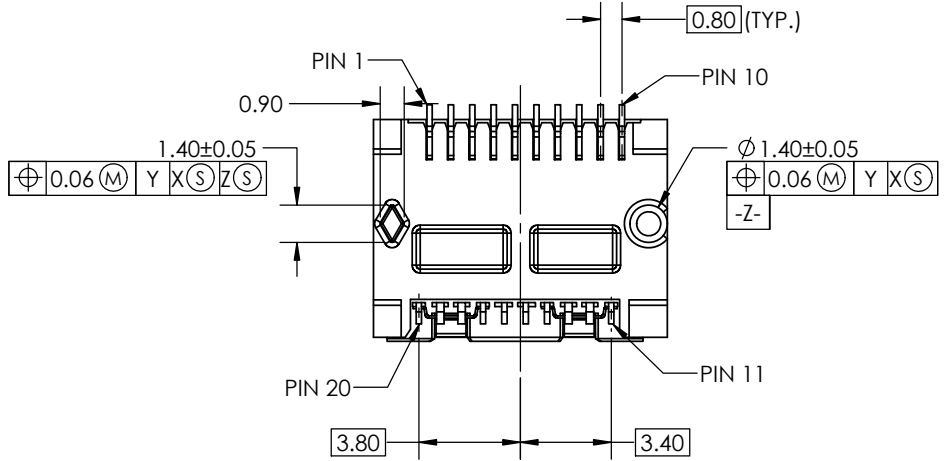

Release Level	In Work	ECN	(ecn)	Amphenol High Speed Interconnects	
Drawn	GALEN LIU	2021-04-27		A Division of Amphenol Corp. www.amphenol-icc.com	
Designed	GALEN LIU	2021-04-27		Title:	
Guardian	MIKE HUANG	2021-04-27		SFP 112G 1XN CONNECTOR ASSEMBLY	
Approver	JASON SI	2021-04-27		Product Family: V76	
				TOLERANCES UNLESS OTHERWISE SPECIFIED	
				Linear	X.X ±0.38 X.XX ±0.25 X.XXX ±0.15
Angular	X° ±2°	Scale: 5:1 Dwg Size: A3 Product - Customer Drw			
				SHEET 2 OF 3	

© 2020 AMPHENOL CANADA CORP.

REVISIONS			
REV.	DESCRIPTION	DATE	APPROVED
-	SEE SHEET1	-	-

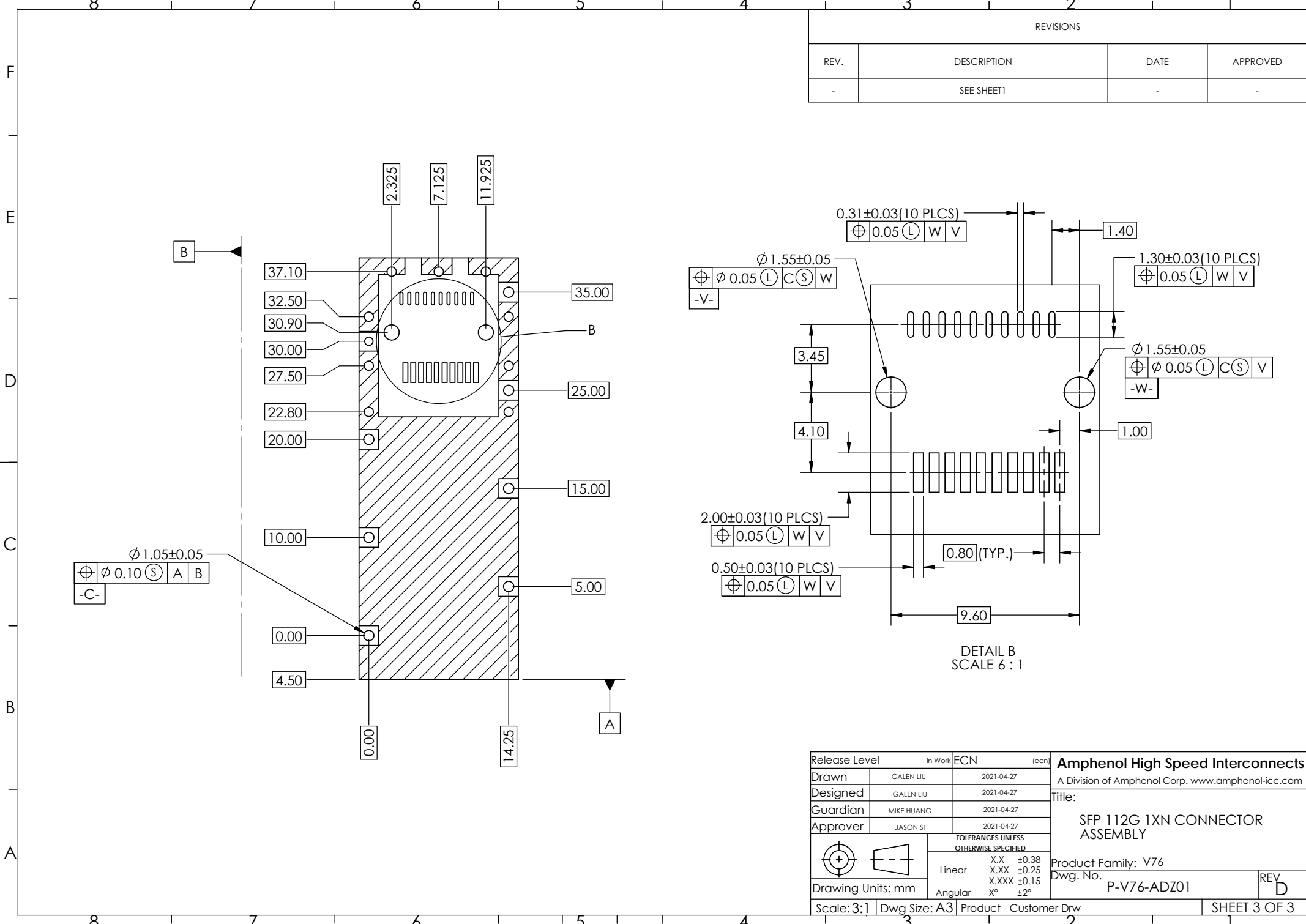

Release Level	In Work	ECN	(ecn)	Amphenol High Speed Interconnects A Division of Amphenol Corp. www.amphenol-icc.com Title: SFP 112G 1XN CONNECTOR ASSEMBLY Product Family: V76 Dwg. No. P-V76-ADZ01
Drawn	GALEN LIU	2021-04-27		
Designed	GALEN LIU	2021-04-27		
Guardian	MIKE HUANG	2021-04-27		
Approver	JASON SI	2021-04-27		
TOLERANCES UNLESS OTHERWISE SPECIFIED Linear X.X ±0.38 X.XX ±0.25 X.XXX ±0.15 Angular X° ±2°				Scale: 3:1 Dwg Size: A3 Product - Customer Drw SHEET 3 OF 3