

This document is the property of Amphenol Corporation and is delivered on the express condition that it is not to be disclosed, reproduced or used, in whole or in part, for manufacture or sale by anyone other than Amphenol Corporation without its prior consent, & that no right is granted to disclose or to use any information in this document.

CUSTOMER DRAWING

REVISIONS				
SYM	ECN	DESCRIPTION	DATE	APPROVED
1	HKXXXX	NEW RELEASE	03/05/18	IP
2	HKXXXX	UPDATED THE DRAWING	05/18/18	IP

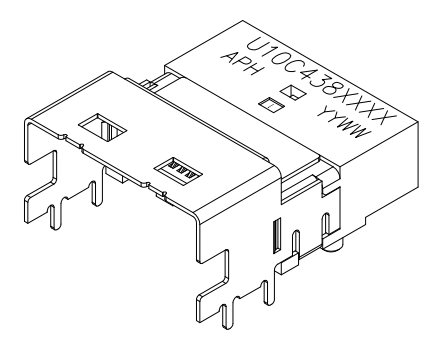
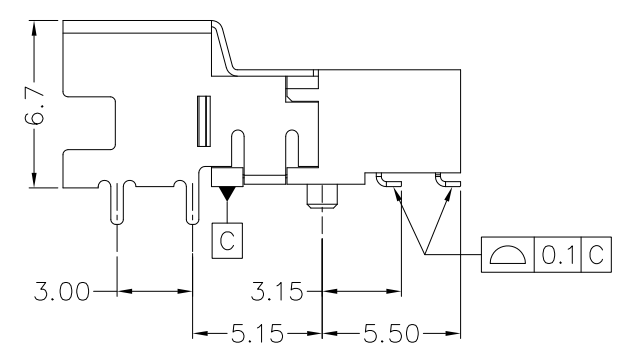
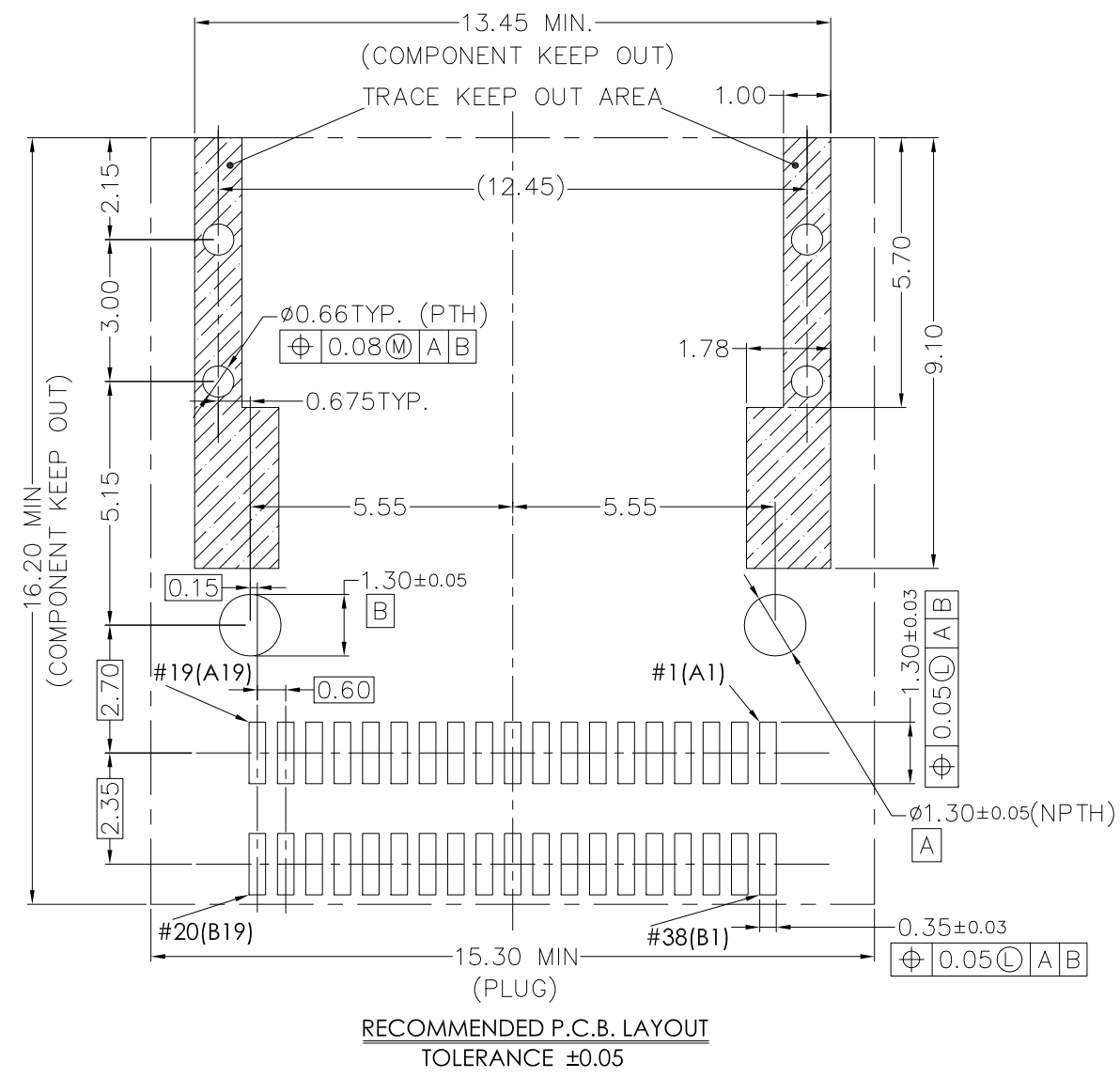
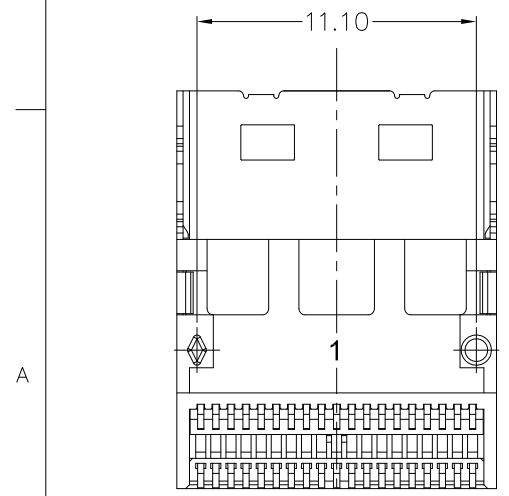
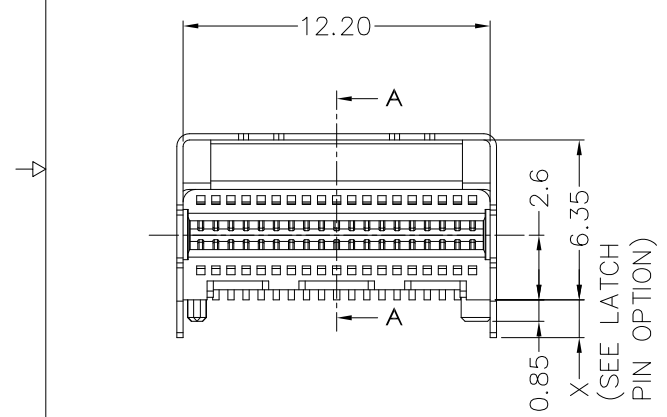
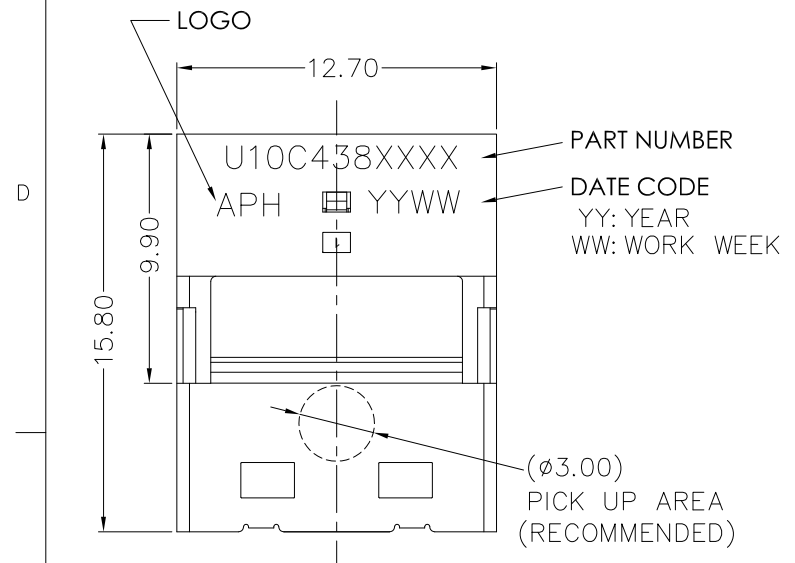

- SPECIFICATIONS:
- Material And Finish:
    - Insulator: High Temperature Thermoplastic UL94 V-0, Black.
    - Contact: Copper Alloy.
    - Gold Plated Over Nickel Plated On Mating Area.
    - Matte Tin Plated Over Nickel On Solder Area.
    - Latch: Stainless Steel.
    - Nickel Plated Overall.
  - Electrical Specification
    - Contact Resistance: 20m Ohms Max.
    - Insulation Resistance: 1000M Ohms Min. At 100V DC For 60 Seconds.
    - Withstanding Voltage: 300V Min. DC For 60 Seconds.
    - Voltage Rating: 30V AC.
    - Current Rating: 0.5A Per Pin.
  - Mechanical Specification
    - Latch Retention Force: 50N Min.
    - Mating Force: 40N Max.
    - Unmating Force: 30N Max.
    - Durability: 250 Cycles.
  - Environmental Specification
    - Operating Temperature: -40° ~ +85°C.
    - Temperature Rise: 30°C Max.
  - RoHS Compliant.

U10 C438 X X X X

- PACKING
  - T: TAPE & REEL
  - 1: TRAY
- SHORTING BAR OPTION
  - 0 = WITH SHORTING BAR
  - 1 = NO SHORTING BAR
- LATCH PIN OPTION
  - 0 = 1.50
  - 4 = 2.20
  - 5 = 3.00
  - 6 = 4.20
- PLATING OPTION
  - 2 = 30 MICRONINCHES OF GOLD
  - 3 = 15 MICRONINCHES OF GOLD

UNLESS OTHERWISE SPECIFIED TOLERANCES

	U.S.	METRIC
.X	+/-	0.35
.XX	+/-	0.25
.XXX	+/-	0.15
FRACTIONS	+/-	
ANGLES	+/-	2'

FOR MATERIALS AND FINISHES SEE NOTES

REMOVE SHARP EDGES

DIMENSIONS

U.S.	INCHES
(METRIC)	(MM)

APPROVAL		DATE
DRAWN	Jason.Yue	05/18/18
CHECKED		
CHECKED		
DRAWING FILE :		
ANGLE OF PROJECTION		

Amphenol		Amphenol East Asia Limited	
TITLE CUSTOMER DRAWING FOR ULTRAPORT SLIMSAS™ 4X24 R/A RECEPTACLE WITH LATCH			
SIZE	DRAWING NO.	REV.	
A3	U10C438XXXX	2	
SCALE	5:1	SHEET 1 OF 1	